

Exhibit Display Rules and Regulations

TCEA Exhibit Display Rules and Regulations function on the principle that all exhibitors should be given an equal opportunity to present their product in the most effective manner. These rules and regulations are designed to ensure this equal opportunity while allowing the greatest flexibility possible within the confines of each exhibit space. The following are specific instructions regarding each type of booth configuration and are subject to the following restrictions.

DISPLAY BOUNDARIES

Exhibit space is sold in 10' x 10' blocks. Booths are created by various combinations of those blocks. Although the spaces are sold as 10' x 10' units, a more accurate width measurement for an interior structure is 9'6" x 9'6", allowing for the pipe and drape. Exhibitors should take this into account when determining the dimensions of their exhibits. Booths have an 8' high draped background with 36" high dividers. Dividers may be removed when two or more connecting booths are purchased by one exhibitor.

No exhibit material may extend beyond the boundaries of the exhibit space or exceed the height restrictions for the type of booth space leased.

INSTALLATION AND REMOVAL OF EXHIBITS

Texas is a right-to-work state, therefore exhibitors may use their own personnel or labor hired from TCEA's official contractor, Freeman, for installing and dismantling exhibits. There are certain exclusive contractors with specific responsibilities for services such as electrical, drayage, cleaning, telecommunications, and catering with which exhibitors must contract. Exhibitors are urged to order any required services in advance to avoid delays. The Exhibitor Services Kit, which will be available to contracted exhibitors in October, will include order forms for these services.

Exhibitors are allowed to appoint firms other than the official contractor to erect and dismantle their booths; however, they are required to notify Exposition Management by completing the appropriate form in the Exhibitor Services Kit. The contractor is also required to show proof of liability coverage before set-up. If Exposition Management does not receive proof, none of the contractors'

employees will be allowed to work in the exhibit hall.

In the sole opinion of Exposition Management, if the exhibitor-appointed contractor's work performance disrupts the orderly installation and removal of exhibits, such firms will be immediately disqualified from working at the exposition site and will be removed from the exhibit hall. The time constraints for installation and dismantling of exhibits and the necessity of opening the exposition on schedule do not allow for disruptions of the planned work schedule. Installation and dismantling of exhibits will be permitted only during the scheduled move-in and move-out times as specified in the conference schedule.

All booth materials must be completely unpacked by 5:00 p.m. on Friday, January 31, to permit removal of cartons from the area. At 5:00 p.m., any booth materials still in crates will be forced set by the official contractor. Exhibitors whose exhibits are forced set will be responsible for labor charges. **ALL BOOTHS MUST BE COMPLETELY INSTALLED AND READY FOR INSPECTION BY 11:00 a.m. ON SUNDAY, FEBRUARY 2.**

Exhibitor move-out begins at 3:30 p.m. on Tuesday, February 4. **NO DISPLAY MAY BE DISMANTLED PRIOR TO THE CLOSE OF THE SHOW.** Exhibitor move-out concludes at 3:00 p.m. on Wednesday, February 5. In the event that exhibit space is not vacated by the exhibitor by 3:00 p.m. on Wednesday, February 5, Exposition Management is authorized to remove, at the expense of the exhibitor, all goods and property of the exhibitor. Exposition Management, or its agents, shall not be liable for any damage or loss to such goods and property, or to the space from which removed, by reason of such removal.

DEMONSTRATIONS

All demonstrations must be confined within the exhibit space. Aisles must not be obstructed at any time. No exhibitor material may extend beyond the boundaries of the exhibit space or exceed the height restrictions for that type of booth. Exposition Management reserves the right to determine if a demonstration interferes with adjacent exhibit spaces and when it must be discontinued. No exhibitor may solicit attendees or distribute literature or other materials outside of their booth space, including but not limited to models, mascots, costumes, uniforms, or any other attire that explicitly draws interest for your company or product, etc.

FLOOR COVERINGS

Exhibitors are required to provide or rent carpet or some other type of floor covering material. The purpose for this is to ensure that the concrete floor displaying the exhibits is covered. Carpet rental order forms will be available in the Exhibitor Services Kit, which will be available to contracted exhibitors in October. Show management will have carpet placed in booths without floor covering by show opening. Exhibitors will be billed for floor coverings ordered by show management.

FOOD AND BEVERAGE

Any food or beverage products to be served in an exhibitor's booth must first be approved by Exposition Management and ordered through Convention Center catering. Submit requests in writing to Exposition Management for approval.

BALLOONS

Static helium balloon displays are allowed in the exhibit hall only as part of a display and must comply with height restrictions for the type of booth(s) reserved, i.e. balloon display may not exceed the 8' height limit for a Linear Booth. Should balloons become detached, exhibitors will be responsible for payment for equipment and labor for balloon retrieval. Exhibitors must request, fill out, and return the Helium Balloon Agreement provided by show management.

VEHICLES

Please contact show management regarding using a vehicle in your exhibit space (gas-powered or electric).

SOUND/MUSIC

Exhibitors may use sound equipment in their booths so long as the noise level does not disrupt the activities of neighboring exhibitors. Exhibitors should remember that using sound equipment is a privilege and not a right. Exposition Management reserves the right to determine at what point sound constitutes interference with others and must be discontinued by adhering to the following:

- Speakers and other sound devices should be positioned so as to direct sound into the booth rather than into the aisle.
- Any sound that consistently exceeds 85 decibels measured at the edge of an exhibitor's booth is considered objectionable.
- There will be two warnings issued about objectionable sound levels exceeding 85dB. Any further objectionable sound levels will result in the exhibitor being required to discontinue the activities responsible for the sound levels exceeding 85dB.
- Exhibitors should be aware that music played in their booths, whether live or recorded, may be subject to laws governing the use of copyrighted compositions. ASCAP, BMI, and SESAC are three authorized licensing organizations that collect copyright fees on behalf of composers and publishers of music.

DRONES/UNMANNED AERIAL VEHICLES (UAV)

Drones or unmanned aerial vehicles (UAV) operations require written approval and compliance with current policies. Contact show management for more information.

HANGING SIGNS

Hanging signs are permitted in Island Booths only and must receive prior approval by Exposition Management. The top of a sign suspended from the exhibit hall ceiling must not exceed 20' from the exhibit hall floor.

Hanging signs must be set back 10' from adjacent booths.

A full description and diagram of the sign must be submitted to Exposition Management for written approval no later than December 13, 2024.

APPROVAL OF BOOTH SCHEMATICS

Exhibitors with island booths of 400 square feet or more, structures exceeding 10 feet in height, and/or two-story booths must submit booth schematics to TCEA Show Management for review and approval by December 13, 2024.

ENGINEERING CERTIFICATION/STRUCTURAL INTEGRITY

Exhibitors are responsible for securing safety certifications from a licensed structural engineer.

Booth structures with towers, columns, and walls that exceed 10 feet in height or two-story exhibits (any height), regardless of whether people will occupy the area, are required to present certification verifying the structural integrity of the exhibit.

Acceptable certification is in the form of a certified structural engineer's stamp or seal directly on a set of blueprints for the exhibit, which are due to TCEA Show Management no later than December 13, 2024.

The engineering certificate must be available on-site to be presented if requested.

Exhibitors must adhere to the rules and regulations of the venue that regulate temporary structures.

This policy has been established to ensure the safety of exhibitors and attendees. Exhibiting companies release TCEA of any and all responsibility for the safety of such exhibits.

CANOPIES/CEILINGS/COVERED EXHIBIT BOOTHS

Exhibit booths with any type of cover, i.e., tents, canopies, awnings, membrane structures etc., must be one hundred square feet (100 sq. ft.) or less; if larger than one hundred square feet (100sq. ft.) the exhibitor must follow the regulations listed below:

- a.** Required approval from the ACC and the AFD Fire Marshal. Fire watch personnel may be required.
- b.** Exhibitor must provide at least one 2A10BC portable, dry chemical fire extinguisher in each covered structure.
- c.** Adjacent tent/canopy groups consisting of multiple smaller tents may not exceed 400 sq. ft. total covered exhibit space in a group without providing a fire break. (12-foot uncovered exhibit space between tent/canopy groups)

Exceptions:

Structures or areas consisting of only noncombustible construction with wholly noncombustible contents and provided with an approved smoke detector.

Exhibit Display Structures

If a structure exceeding 400 sq. ft. has a roof and is composed of combustible material or has combustible contents, a sprinkler system is required.

Exceptions:

Structures or areas consisting of only noncombustible construction with wholly noncombustible contents and provided with an approved smoke detector.

FIRE SAFETY

All local and/or state fire and safety regulations will be strictly enforced, and it is the responsibility of the exhibitor to comply with these regulations. A full set of the Fire and Safety Regulations can be found at the venue Site.

VARIANCES

Any exceptions or alterations to the restrictions and boundaries described herein must meet with the approval of Exposition Management and must be obtained prior to the booth set-up. If Exposition Management determines that your exhibit obstructs or interferes in any way with other exhibits in the area, you will be asked to conform to the rules during the Exposition. If you are unable to comply with the rules, you may be instructed to dismantle your booth or the part of the booth that does not conform. Exposition Management will not give refunds to any exhibitors asked to dismantle their exhibits.

WIRELESS

The Austin Convention Center Department (ACCD) is the exclusive provider of wired and wireless (Wi-Fi) services for the Austin Convention Center and Palmer Events Center. The ACCD Wi-Fi service offers Internet access at speeds of up to 3 Mbps per device connected and is used to service clients, exhibitors, and attendees. The wireless signal available in the exhibit halls will only broadcast the 5 GHz spectrum and will not support any 2.4 GHz devices. Wireless devices such as Wi-Fi routers, wireless access points, personal Wi-Fi hotspots, or other wireless peripherals attempting to be used by attendees or exhibitors are considered rogue devices. Rogue devices can cause problems and degrade performance for attendees and exhibitors attempting to use the ACCD wireless. The ACCD can assist TCEA show management with detecting and locating such devices, and the user can be asked by TCEA staff to discontinue the use of the device. If you are conducting a product demonstration, presentation, or streaming video over the Internet, we strongly recommend the purchase of a wired Internet connection. If you have any concerns regarding your booth's communication needs, please contact Exposition Management.

AMERICANS WITH DISABILITIES ACT (ADA)

All exhibiting companies are required to be in compliance with the Americans with Disabilities Act (ADA) and are encouraged to be sensitive and as reasonably accommodating as possible, to attendees with disabilities. Information regarding ADA compliance is available from the U.S. Department of Justice ADA Information Line (800) 514-0301 and the ADA website at www.ada.gov.

Exhibitors must adhere to the ADA rules to avoid heavy fines by the U. S. Department of Justice. Exhibits are not exempt from ADA compliance.

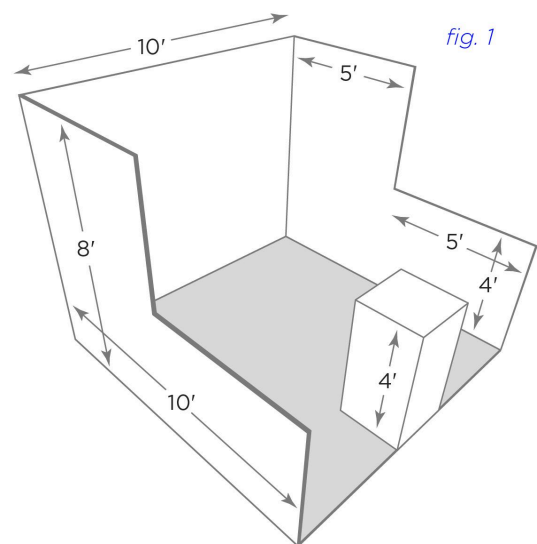

LINEAR BOOTH (IN-LINE BOOTH)

See Figure 1.

Definition

Linear Booths have only one side exposed to an aisle and are generally arranged in a series along a straight line.

Dimensions

A maximum height of eight feet (8') is allowed only in the rear half of the booth space, with a

four foot (4') height restriction imposed on all materials in the remaining space forward to the aisle. (Note: When three or more Linear Booths are used in combination as a single exhibit space, the four foot (4') height limitation is applied only to that portion of exhibit space which is within ten feet (10') of an adjoining booth.)

PREMIUM CORNER BOOTH

See Figure 1.

Definition

A Corner Booth is a Linear Booth exposed to aisles on two sides. All other guidelines for Linear Booths apply.

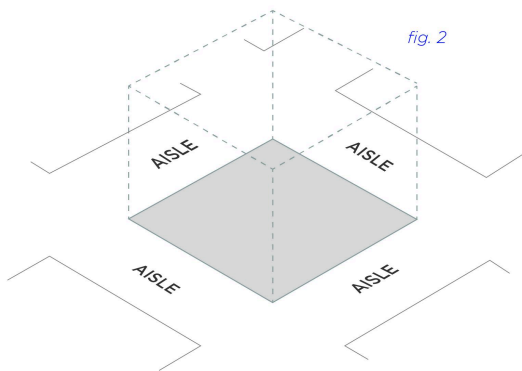

ISLAND BOOTH

See Figure 2.

Definition

An Island Booth is any size booth exposed to aisles on all four sides.

Dimensions

An Island Booth is typically 20' x 20' or larger, although it may be configured differently. The entire cubic content of the space may be used up to the maximum allowable height of twenty feet (20'), including signage.

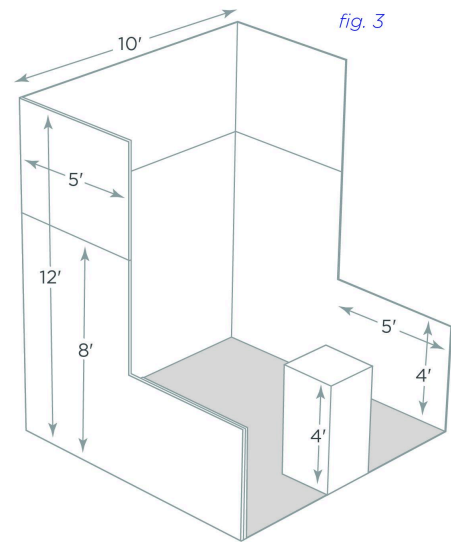

PERIMETER BOOTH

See Figure 3.

Definition

A Perimeter Booth is simply a Linear Booth that backs to a wall of the exhibit facility rather than to another exhibit.

Dimensions

All guidelines for Linear Booths apply to Perimeter Booths except that the maximum backwall height is twelve feet (12').

PENINSULA BOOTH

Definition

A Peninsula Booth is exposed to aisles on three sides and composed of a minimum of four booths.

Dimensions

A Peninsula Booth is usually 20' x 20' or larger. Because a Peninsula Booth backs up to two Linear Booths, the backwall is restricted to four feet (4') high within five feet (5') of each aisle, permitting adequate line of sight for the adjoining Linear Booths. Sixteen feet (16') is the maximum height allowance, including signage for the center portion of the backwall.

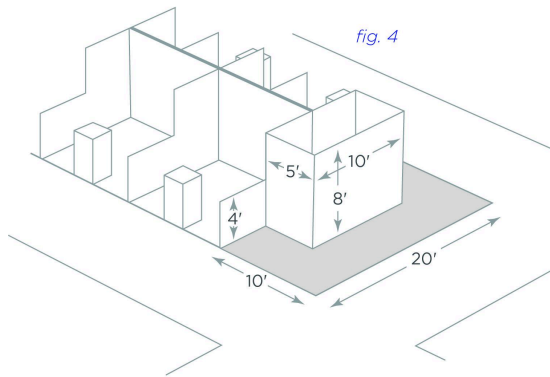

END-CAP BOOTH

See Figure 4.

Definition

An End-cap Booth is exposed to aisles on three sides and composed of two booths.

Dimensions

End-cap Booths are generally ten feet (10') deep by twenty feet (20') wide. The maximum backwall height of eight feet (8') is allowed only in the rear half of the booth space and within five feet (5') of the two side aisles with a four foot (4') height restriction imposed on all materials in the remaining space forward to the aisle.

CONTACT

Sammy Unberhagen
Director of Exhibits, Sponsorships, and Events
sunberhagen@tcea.org
(800) 282-8232 x5390